

NOTE:  
 ALL RIGHTS RESERVED. THIS DRAWING OR ANY PART THEREOF MUST NOT BE REPRODUCED IN ANY FORM WITHOUT THE WRITTEN PERMISSION OF AREO-POWER UNITIZED FUELER  
 AREO-POWER SHALL BE RESPONSIBLE ONLY FOR ITEMS INDICATED ON THIS FABRICATION DRAWING UNLESS OTHERWISE NOTED. CUSTOMER IS RESPONSIBLE FOR VERIFYING CORRECTNESS OF SIZE / LOCATION OF FITTINGS, ACCESSORIES & COATINGS SHOWN ON THIS DRAWING

3" LIGHTWEIGHT INSULATION MATERIAL WITHIN INTERSTICE

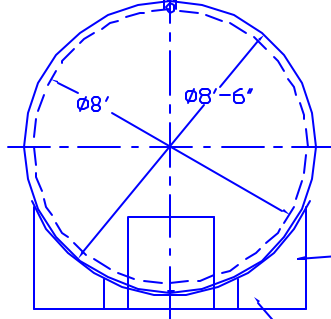

2" HOLE FOR SHIPMENT BANDING. (2) TYP PER SADDLE

SADDLES ARE STI SPEC 6" HIGH SADDLES ARE SEAL WELDED TO TANK

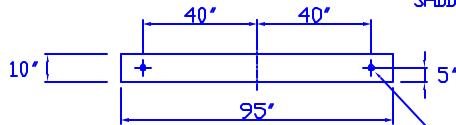

2"Ø HOLES TYP

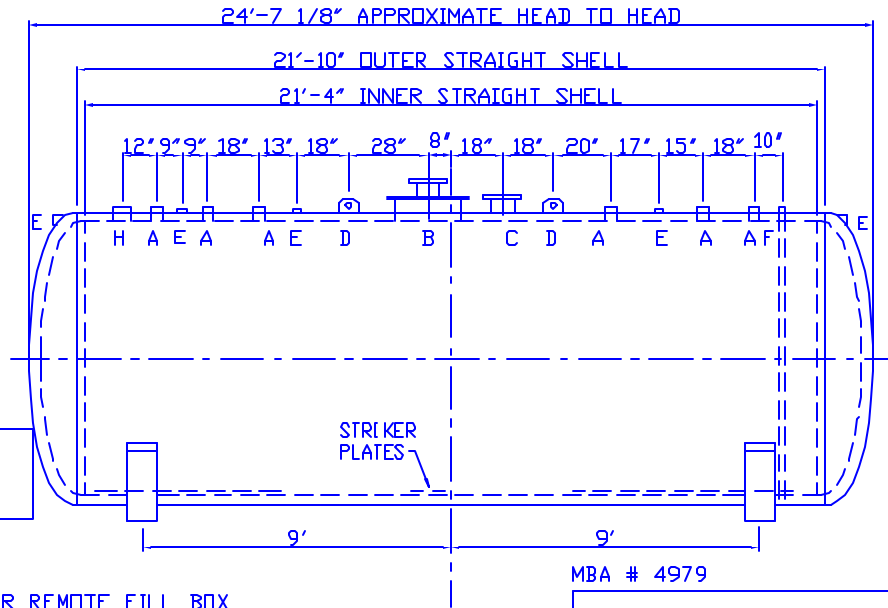

STRIKER PLATES

BAKER REMOTE FILL BOX

MBA # 4979

CAPACITY - 8,000 GALLONS

MATERIAL - MILD CARBON STEEL

THICKNESS - INNER SHELL - 1/4"  
 OUTER SHELL - 1/4"

HEADS - INNER - 5/16" MIN. STD FLG'D & DISHED  
 OUTER - 5/16" MIN. STD FLG'D & DISHED

CONSTRUCTION - INNER & OUTER - LAP WELD OUTSIDE ONLY

TEST - INNER - 20 PSIG HYDROTEST  
 OUTER - 5 PSIG AIR

PAINT - INT - NONE

EXT - SSPC SP6 BLAST, EPOXY PAINT SYSTEM, COLOR TO BE WHITE

LABEL - UL 2085, FIREGUARD, AND NEW YORK CITY

A 4" FEMALE FG COUPLING

B 8" X 150# RFSD FLANGE MOUNTED IN 24" X 1/2" THICK PLATE  
 MANWAY - PRIMARY EMERGENCY VENT USE

C 8" X 150# RFSD FLANGE THROUGH OUTER SHELL ONLY - INTERSTICE EMERGENCY VENT USE

D LIFT LUG

E 2" FNPT THROUGH OUTER SHELL ONLY WITH CAST IRON PLUG - FOR MFG USE ONLY

F 2" MONITOR PIPE MALE NPT END

G 2" FITTING THROUGH OUTER SHELL ONLY

H 6" FEMALE FG COUPLING

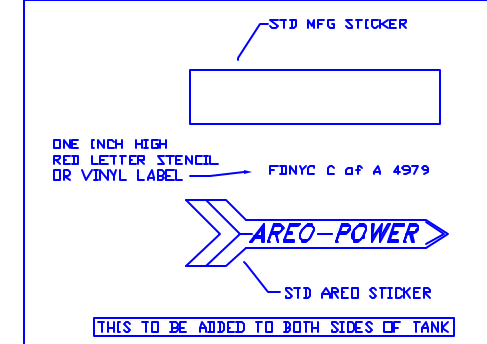

<b>AREO-POWER</b> ®				
8000 GAL 96"Ø FIREGUARD®				
NEW YORK CITY STYLE				
CUSTOMER: ---				
PROJECT: ---				
QUOTE NO: ---				
SCALE 1/4" = 1'-0"	DATE 09/13/02	DRAWN BY 001	CHK'D BY	ENG NO 8KFGNYCFD