

DRAWING TITLE

NEW YORK CITY
240 GAL U/G
TYPE 1 DW

NOTE :
ALL RIGHTS RESERVED. THIS DRAWING OR ANY PART THEREOF MUST
NOT BE REPRODUCED IN ANY FORM WITHOUT THE WRITTEN PERMISSION
OF HIGHLAND TANK.
HIGHLAND TANK SHALL BE RESPONSIBLE ONLY FOR ITEMS INDICATED
ON THIS FABRICATION DRAWING UNLESS OTHERWISE NOTED. CUSTOMER
IS RESPONSIBLE FOR VERIFYING CORRECTNESS OF SIZE / LOCATION
OF FITTINGS, ACCESSORIES & COATINGS SHOWN ON THIS DRAWING

FITTING SCHEDULE

- A= 3" # NPT WITH 3" x 2" NYLON BUSHING
- B= 3" # NPT WITH 3" x 2" NYLON BUSHING
(FITTING FOR LEAK DETECTION W/ INTERNAL PPE)
- C= 3" # NPT WITH 3" x 4" NYLON BUSHING

GENERAL NOTES

CAPACITY : 240 GALLONS
TYPE : 1 360 DOUBLE WALL, UNDERGROUND, NY CITY
NO. REQ. :
MATERIAL : MILD CARBON STEEL
TEST : 30 P.S.I. INNER 6 P.S.I. OUTER
MIN. GAUGE OR THICKNESS (PER U.L. 58) :
(BASED ON 60" MAX. BURIAL DEPTH)
INNER HEADS : 3/16" OUTER HEADS : 10 GA.
INNER SHELL : 1/4" OUTER SHELL : 10 GA.
PAINT :

- INTERIOR : NONE
- EXTERIOR : SP-6 BLAST, COAT WITH :
 - CORROCDTE PLUS 15 MILS
 - POLYURETHANE 70 MILS
 - FIBERGLASS REINFORCED POLYESTER 125 MILS

CONSTRUCTION : FLANGED & DISHED HEADS, LAP WELD
ALL EXTERIOR SEAMS ONLY
APPROVED LABELS : U.L. 58, NYC, NYCRR PART #14

- S.T.J.P.3
- ACT-100-U
- ACT-100

- 18000 VOLT SPARK TEST PROVIDED AT FACTORY FOR POLYURETHANE MODELS
- 35000 VOLT SPARK TEST PROVIDED AT FACTORY FOR F.R.P. MODELS

REVISION DESCRIPTION
BY
DATE
REV

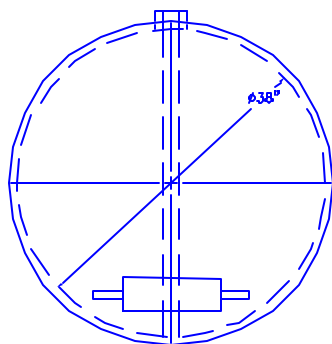

END VIEW

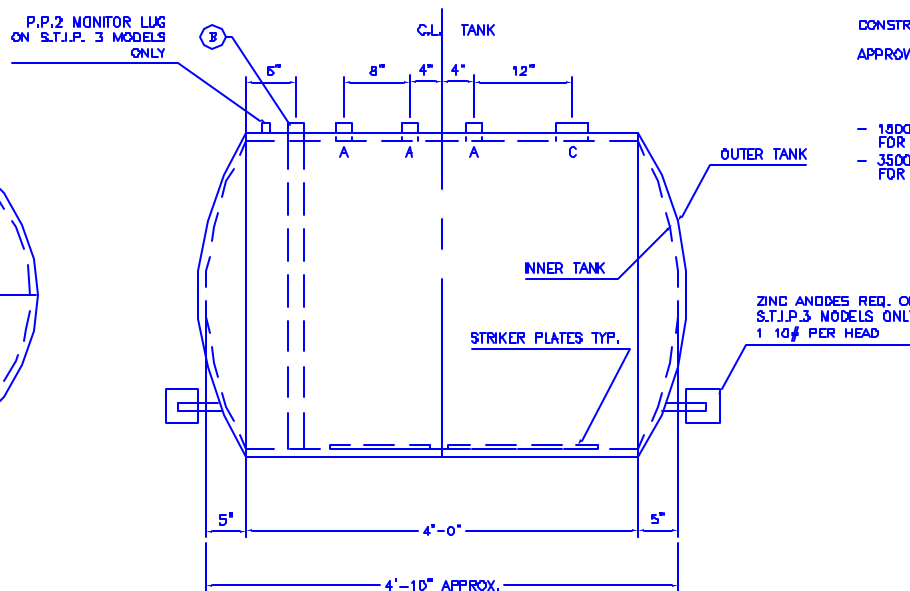

ELEVATION

ALL RIGHTS RESERVED. THIS DRAWING OR ANY PART THEREOF MUST NOT BE REPRODUCED IN ANY FORM WITHOUT WRITTEN PERMISSION OF AREO-POWER UNITIZED FUELER, INC.

DWG NO: 240 DWINYCLUG
SCALE: 3/4"=1" DWN BY: HT
SHEET: 1 DATE: 11/1/02