

DESIGN DATA

CAPACITY : 5,000 GALLON
TYPE: FIREGUARD® CYLINDRICAL
FIREGUARD® IS A TRADEMARK OF THE STEEL TANK INSTITUTE
NO. REQ. --
OPERATING PRESSURE -- ATMOSPHERIC
TANK MATERIAL -- MILD CARBON STEEL
THICKNESS -- INNER-- HEADS: 5/16", SHELL: 1/4"
THICKNESS -- OUTER-- HEADS: 5/16", SHELL: 1/4"
MIN. GAUGE OR THICKNESS (PER U.L. 2085)
CONSTRUCTION -- INNER -- LAP WELD OUTSIDE ONLY
CONSTRUCTION -- OUTER -- LAP WELD OUTSIDE ONLY
TANK TEST -- PER UL 2085
INT. FINISH -- NONE
EXT. FINISH -- SP-6 BLAST, FINISH PAINT WHITE
LABEL-- UL 2085 AND FIREGUARD® PER stl

NOTE: ALL RIGHTS RESERVED. THIS DRAWING MUST NOT BE REPRODUCED IN ANY FORM WITHOUT THE WRITTEN PERMISSION OF AREO-POWER®. AREO-POWER® SHALL BE RESPONSIBLE ONLY FOR ITEMS INDICATED ON THIS FABRICATION DRAWING UNLESS OTHERWISE NOTED. CUSTOMER IS RESPONSIBLE FOR VERIFYING CORRECTNESS OF SIZE AND LOCATION OF FITTINGS, ACCESSORIES, AND COATINGS SHOWN ON THIS DRAWING.

TOUCH UP OF FINISHED PAINT IS REQUIRED BY INSTALLATION CONTRACTOR. TOUCH UP PAINT SHIPPED WITH TANK.

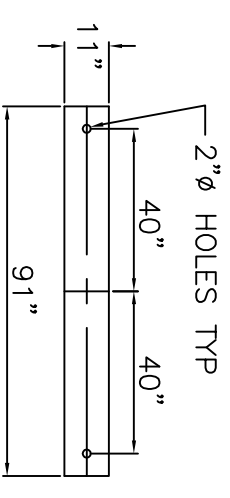
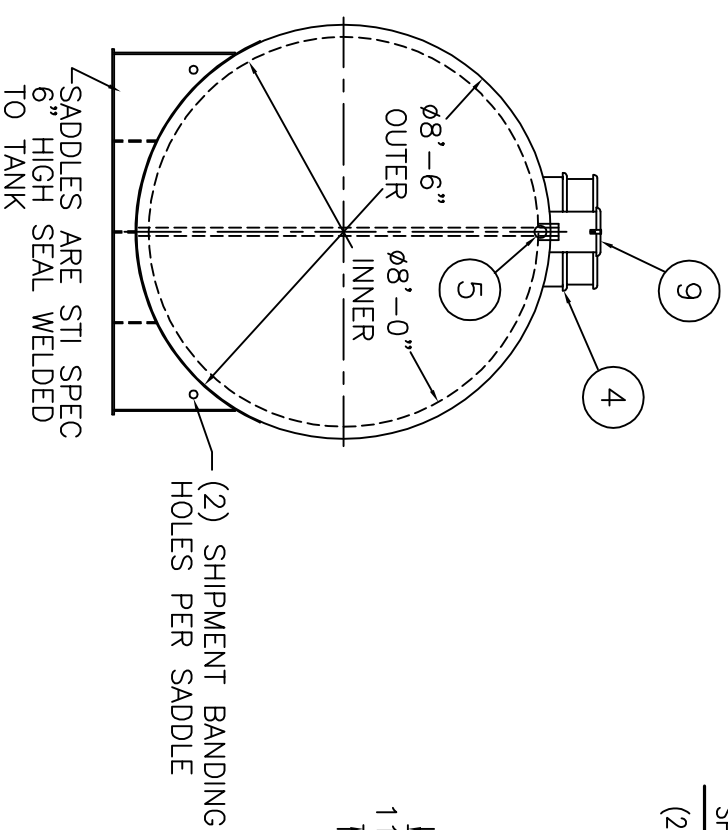
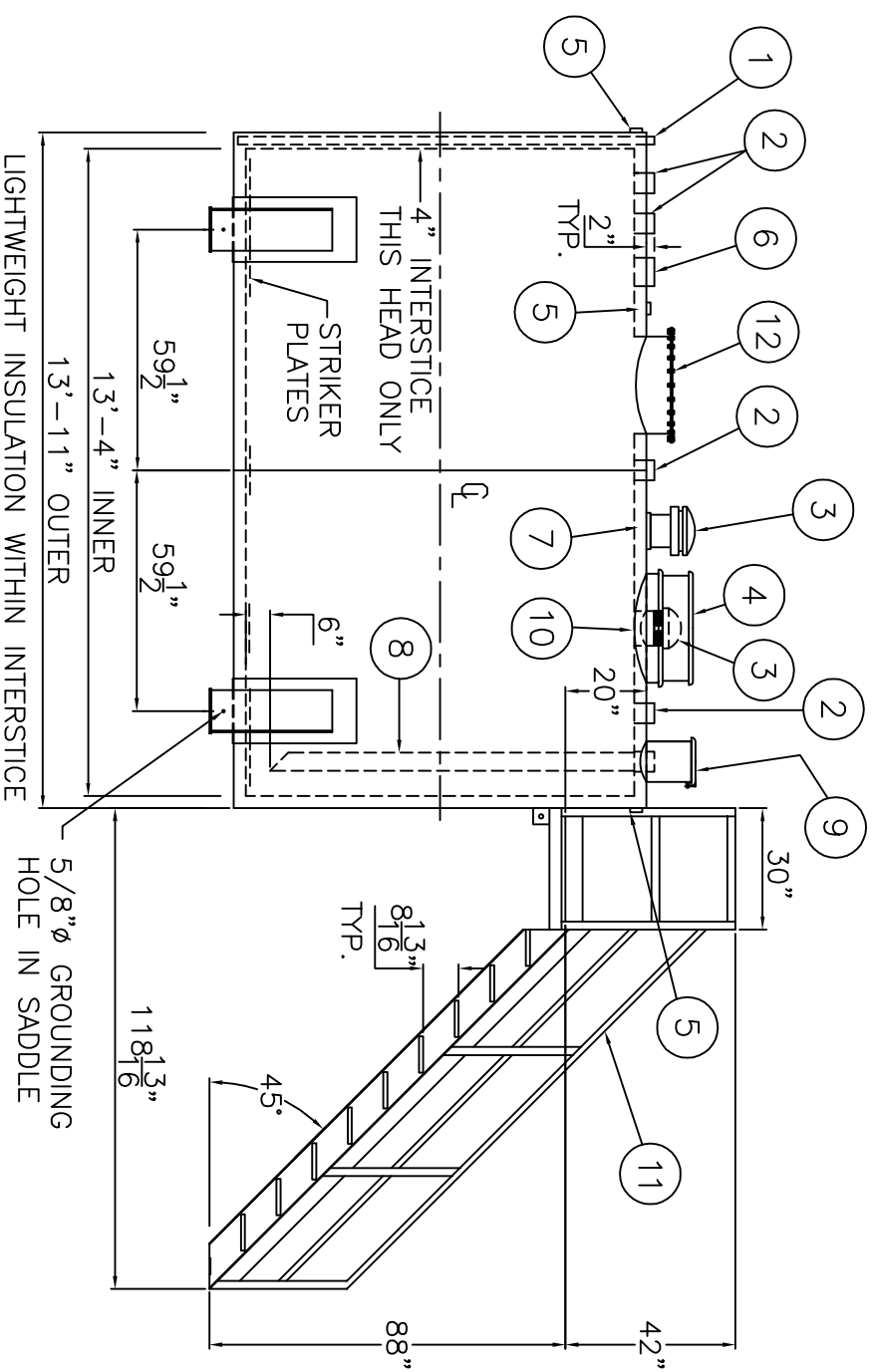
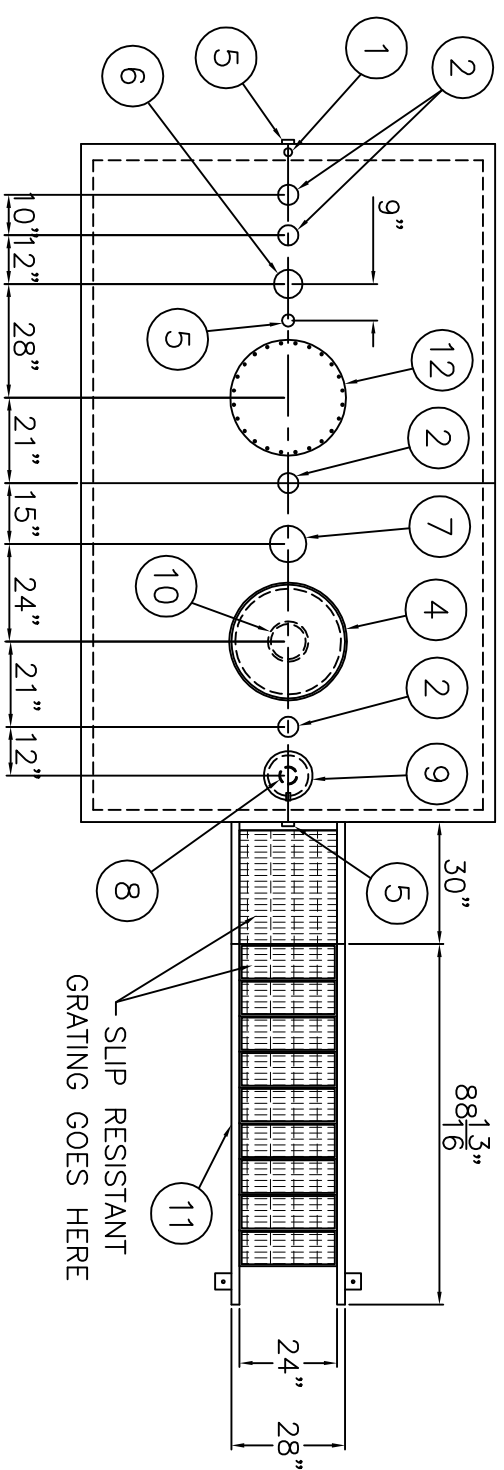

SHIP LOOSE
 (2) 8" MALE THREADED EMERGENCY VENTS

ITEM	QTY	DESCRIPTION	ITEM	QTY	DESCRIPTION
1	1	2" MONITOR PIPE WITH MALE NPT END	7	1	8" FITTING THROUGH OUTER SHELL ONLY, MARK WITH SPECIAL WARNING LABEL. INTERSTITIAL EMERGENCY VENT USE ONLY
2	4	4" FEMALE FG COUPLING	8	1	4" FEMALE FIREGUARD COUPLING w/ 4" DROP PIPE TO WITHIN 6" OF THE BOTTOM OF THE TANK WITH 45° MITER
3	2	8" EMERGENCY VENT	9	1	FILL CONTAINMENT CHAMBER
4	1	EMERGENCY VENT PROTECTION HOOD	10	1	8" FEMALE FG COUPLING (PRIMARY VENT USE)
5	3	2" FITTING THROUGH OUTER SHELL ONLY WITH CAST IRON PLUG-- MFG USE ONLY			
6	1	6" FEMALE FG COUPLING			

AREO-POWER ®

PATENT NUMBER 5346093

5,000 GAL 96" Ø CYL. FIREGUARD®

PATENT: 5,695,089 PATENT: 5,809,650

CUSTOMER:

PROJECT:

QUOTE NO:

SCALE: 1/4"=1'-0"

CHK'D BY: _____
 DWG. NO.: AP5000FG96CYL