

NOTE: ALL RIGHTS RESERVED. THIS DRAWING MUST NOT BE REPRODUCED IN ANY FORM WITHOUT THE WRITTEN PERMISSION OF AREO-POWER®. AREO-POWER® SHALL BE RESPONSIBLE ONLY FOR ITEMS INDICATED ON THIS FABRICATION DRAWING UNLESS OTHERWISE NOTED. CUSTOMER IS RESPONSIBLE FOR VERIFYING CORRECTNESS OF SIZE AND LOCATION OF FITTINGS, ACCESSORIES, AND COATINGS SHOWN ON THIS DRAWING.

TOUCH UP OF FINISHED PAINT IS REQUIRED BY INSTALLATION CONTRACTOR. TOUCH UP PAINT SHIPPED WITH TANK.

- SHIP LOOSE
- (2) 6" MALE THREADED EMERGENCY VENTS
  - (1) VENT DEFLECTOR

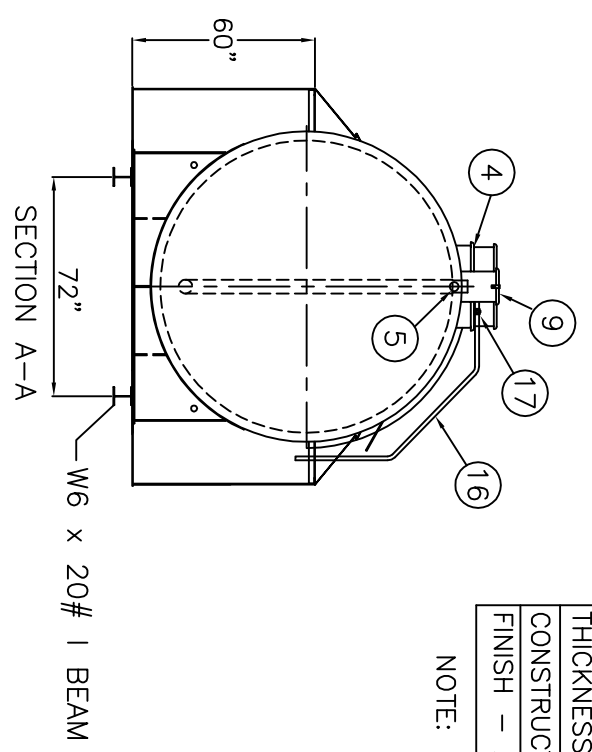
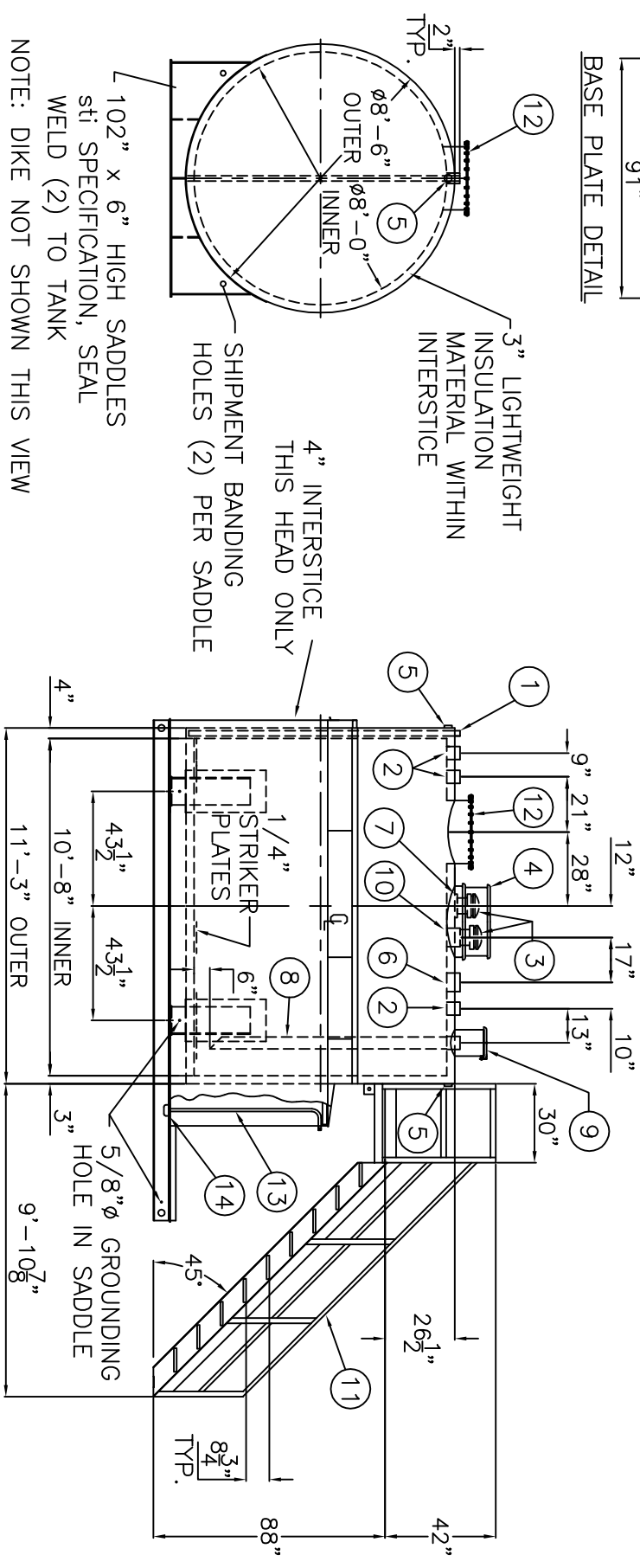
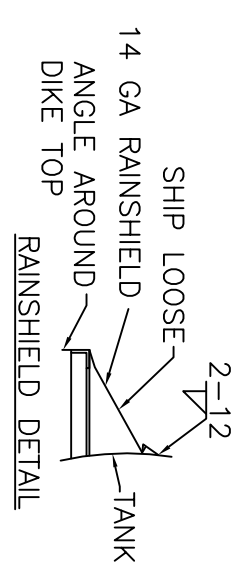
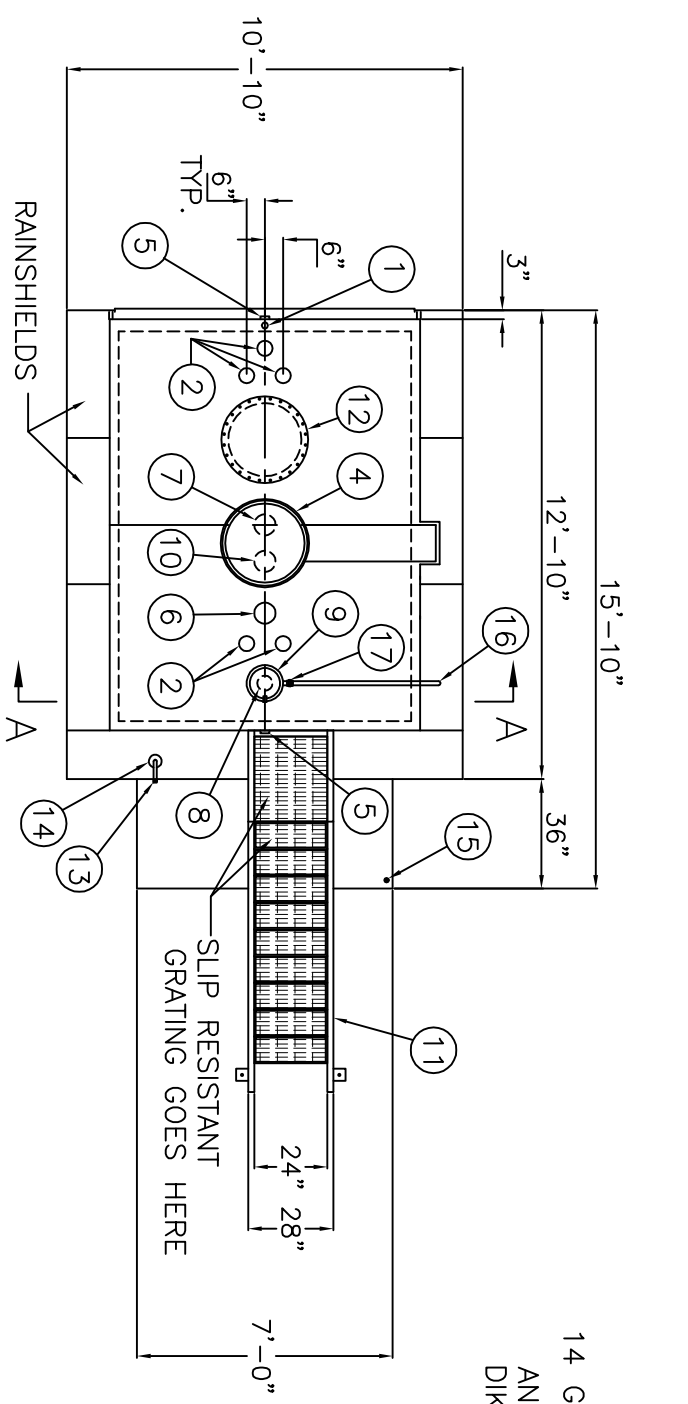

NOTE: DIKE NOT SHOWN THIS VIEW

ITEM	QTY	DESCRIPTION	ITEM	QTY	DESCRIPTION	ITEM	QTY	DESCRIPTION
1	1	2" MONITOR PIPE WITH MALE NPT END	7	1	6" FITTING THROUGH OUTER SHELL ONLY, MARK WITH SPECIAL WARNING LABEL INTERSTITIAL EMERGENCY VENT USE ONLY	12	1	24" x 1/4" PLATE TIGHT BOLT MANWAY WITH 1/8" THICK NEO-CORK GASKET
2	5	4" FEMALE FG COUPLING	8	1	4" FEMALE FG COUPLING w/ 4" DROP PIPE TO WITHIN 6" OF THE BOTTOM OF THE TANK, MITER 45°	13	1	3/4" PUMPOUT PIPE
3	2	6" EMERGENCY VENT (SHIP LOOSE)	9	1	FILL CONTAINMENT CHAMBER	14	1	3" PIPE CAP SUMP
4	1	EMERGENCY VENT PROTECTION HOOD	10	1	6" FEMALE FG COUPLING (PRIMARY VENT USE)	15	1	1/2" DRAIN FITTING
5	2	2" FITTING THROUGH OUTER SHELL ONLY WITH CAST IRON PLUG - MFG USE ONLY	11	1	24" WIDE x 88" STAIRS w/ 1" FIBERGLASS GRATING, BOLT TO TANK, PAINT: SAFETY YELLOW, SHIP LOOSE, INSTALLATION ON SITE BY OTHERS.	16	1	1" OVER FLOW PIPE
6	1	6" FEMALE FG COUPLING				17	1	1" PIPE UNION

**DESIGN DATA**

CAPACITY : 4,000 GALLON

TYPE: FIREGUARD® CYLINDRICAL

FIREGUARD® IS A TRADEMARK OF THE STEEL TANK INSTITUTE

NO. REQ. --

OPERATING PRESSURE -- ATMOSPHERIC

TANK MATERIAL -- MILD CARBON STEEL

THICKNESS -- INNER-- HEADS: 5/16", SHELL: 1/4" THICKNESS -- OUTER-- HEADS: 5/16", SHELL: 1/4" MIN. GAUGE OR THICKNESS (PER U.L. 2085)

CONSTRUCTION -- INNER -- LAP WELD OUTSIDE ONLY CONSTRUCTION -- OUTER -- LAP WELD OUTSIDE ONLY

TANK TEST -- PER UL 2085

INT. FINISH -- NONE

EXT. FINISH -- SP-6 BLAST, FINISH PAINT WHITE

LABEL -- UL 2085 AND FIREGUARD® PER st

**DIKE DESIGN DATA**

CAPACITY -- 5,200 GALLONS

TANK MATERIAL -- MILD CARBON STEEL

THICKNESS -- ALL -- 1/4"

CONSTRUCTION -- WELDED INSIDE & OUTSIDE

FINISH -- ALL -- SAME AS TANK EXTERIOR

NOTE: ALL DIMENSIONS APPROXIMATE

**AREO-POWER®**

PATENT NUMBER 5346093

4,000 GAL 96" Ø CYL. FIREGUARD®

PATENT: 5,695,089 PATENT: 5,809,650

CUSTOMER:

PROJECT:

QUOTE NO:

SCALE: DATE: DIV. BY: DIV. NO:

3/16"=1'-0" AP4000FCG96DIKE