

NOTE: ALL RIGHTS RESERVED. THIS DRAWING MUST NOT BE REPRODUCED IN ANY FORM WITHOUT THE WRITTEN PERMISSION OF AREO-POWER®. AREO-POWER® SHALL BE RESPONSIBLE ONLY FOR ITEMS INDICATED ON THIS FABRICATION DRAWING UNLESS OTHERWISE NOTED. CUSTOMER IS RESPONSIBLE FOR VERIFYING CORRECTNESS OF SIZE AND LOCATION OF FITTINGS, ACCESSORIES, AND COATINGS SHOWN ON THIS DRAWING.

TOUCH UP OF FINISHED PAINT IS REQUIRED BY INSTALLATION CONTRACTOR. TOUCH UP PAINT SHIPPED WITH TANK.

SHIP LOOSE

- (2) 8" MALE THREADED EMERGENCY VENTS
- (1) VENT DEFLECTOR

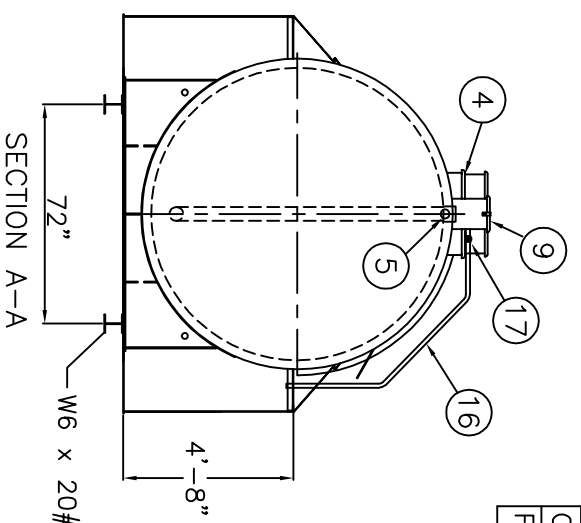
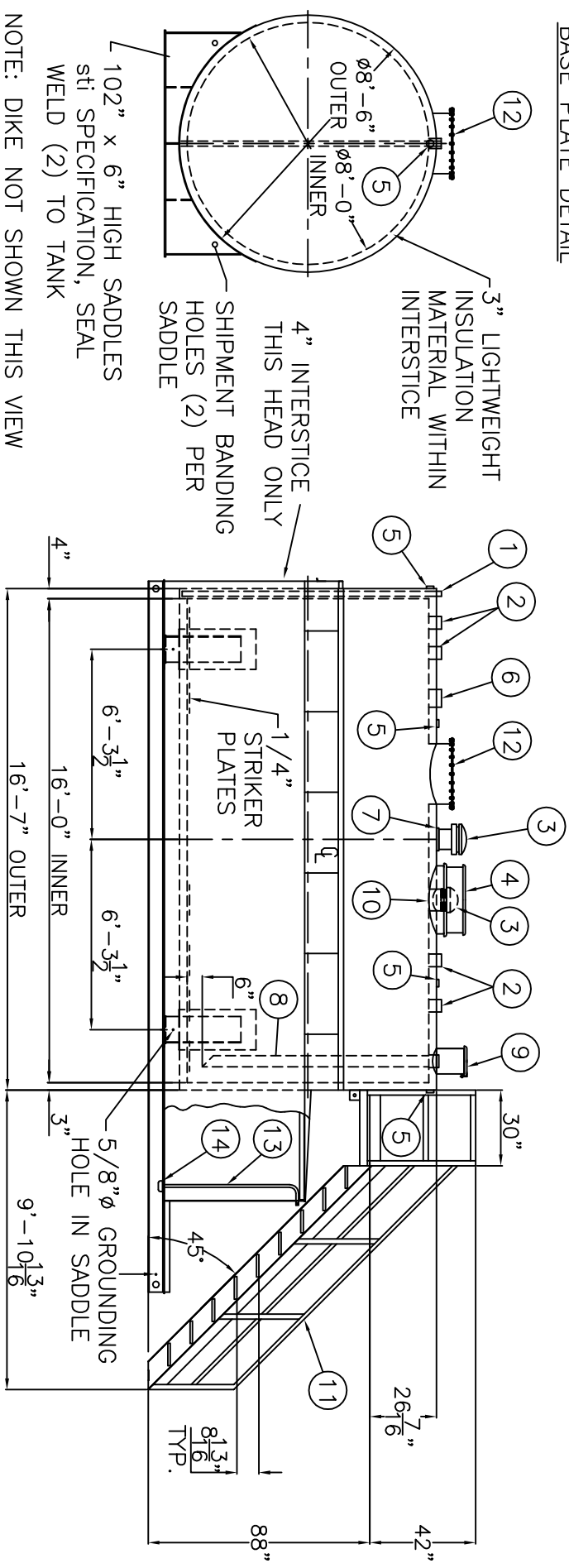
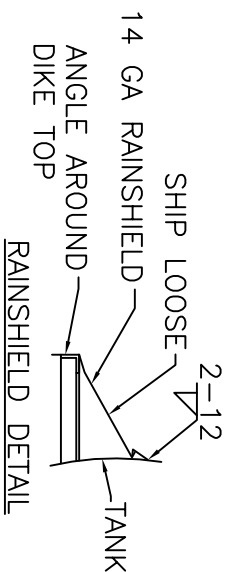
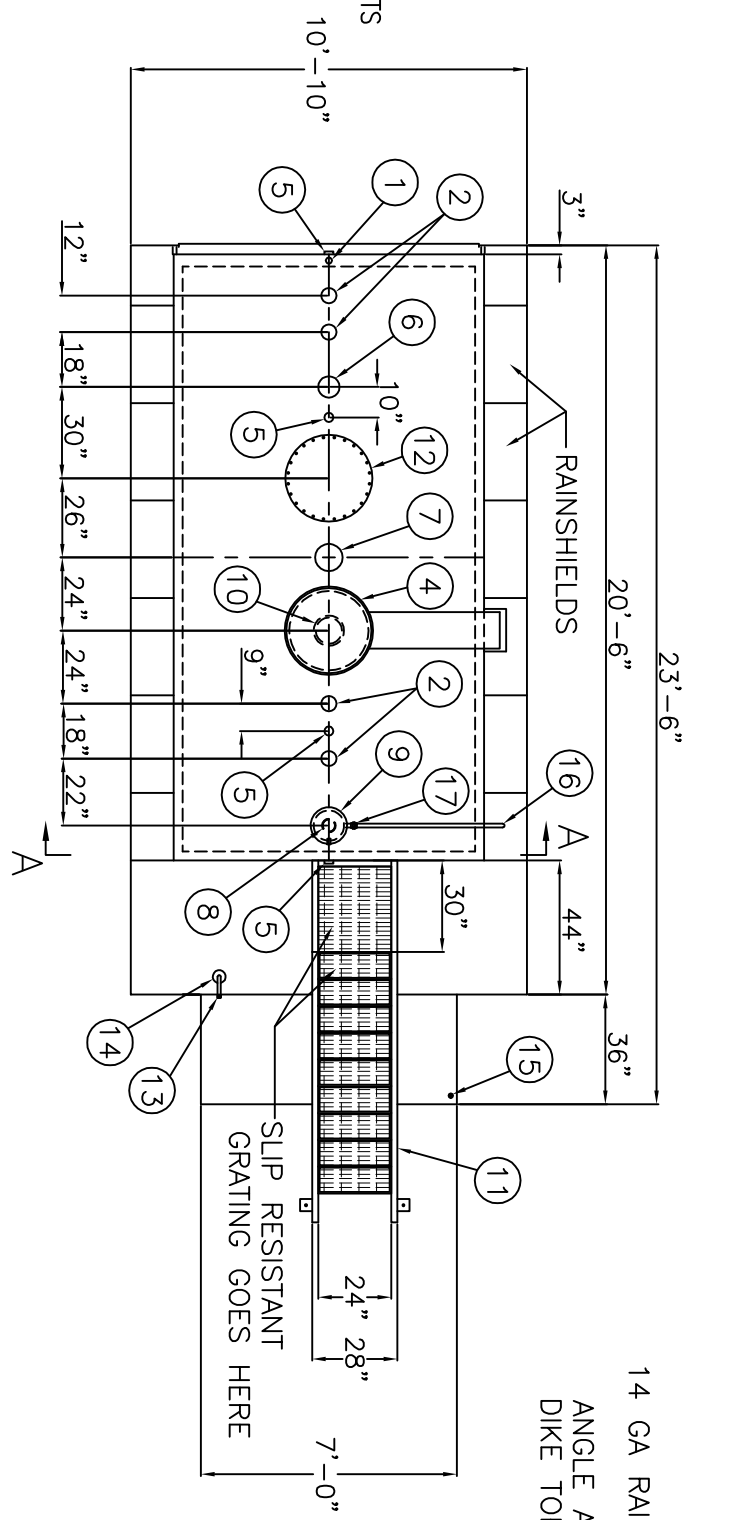
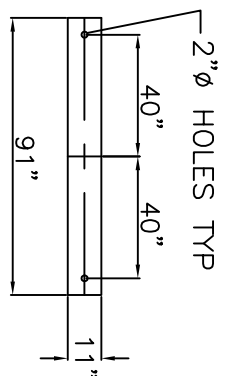

ITEM	QTY	DESCRIPTION	ITEM	QTY	DESCRIPTION	ITEM	QTY	DESCRIPTION
1	1	2" MONITOR PIPE WITH MALE NPT END	7	1	8" FITTING THROUGH OUTER SHELL ONLY, MARK WITH SPECIAL WARNING LABEL INTERSTITIAL EMERGENCY VENT USE ONLY	12	1	24" x 1/4" PLATE TIGHT BOLT MANWAY WITH 1/8" THICK NEO-CORK GASKET
2	4	4" FEMALE FG COUPLING	8	1	4" FEMALE FG COUPLING W/ 4" DROP PIPE TO WITHIN 6" OF THE BOTTOM OF THE TANK, MITER 45°	13	1	3/4" PUMPOUT PIPE
3	2	8" EMERGENCY VENT (SHIP LOOSE)	9	1	FILL CONTAINMENT CHAMBER	14	1	3" PIPE CAP SUMP
4	1	EMERGENCY VENT PROTECTION HOOD	10	1	8" FEMALE FG COUPLING (PRIMARY VENT USE)	15	1	1/2" DRAIN FITTING
5	4	2" FITTING THROUGH OUTER SHELL ONLY WITH CAST IRON PLUG- MFG USE ONLY	11	1	24" WIDE x 88" STAIRS W/ 1" FIBERGLASS GRATING, BOLT TO TANK, PAINT: SAFETY YELLOW, SHIP LOOSE, INSTALLATION ON SITE BY OTHERS.	16	1	1" OVER FLOW PIPE
6	1	6" FEMALE FG COUPLING	17	1	1" PIPE UNION	17	1	1" PIPE UNION

DESIGN DATA	
CAPACITY :	6,000 GALLON
TYPE:	FIREGUARD® CYLINDRICAL
FIREGUARD® IS A TRADEMARK OF THE STEEL TANK INSTITUTE	
NO. REQ. --	--
OPERATING PRESSURE --	ATMOSPHERIC
TANK MATERIAL --	MILD CARBON STEEL
THICKNESS --	INNER- HEADS: 5/16", SHELL: 1/4" THICKNESS - OUTER- HEADS: 5/16", SHELL: 1/4" MIN. GAUGE OR THICKNESS (PER U.L. 2085)
CONSTRUCTION --	INNER - LAP WELD OUTSIDE ONLY CONSTRUCTION - OUTER - LAP WELD OUTSIDE ONLY
TANK TEST --	PER UL 2085
INT. FINISH --	NONE
EXT. FINISH --	SP-6 BLAST, FINISH PAINT WHITE
LABEL --	UL 2085 AND FIREGUARD® PER stl

DIKE DESIGN DATA	
CAPACITY --	7,700 GALLONS
TANK MATERIAL --	MILD CARBON STEEL
THICKNESS --	ALL - 1/4"
CONSTRUCTION --	WELDED INSIDE & OUTSIDE
FINISH --	ALL - SAME AS TANK EXTERIOR

NOTE: ALL DIMENSIONS APPROXIMATE

**AREO-POWER** ®

PATENT NUMBER 5346093

6,000 GAL 96" Ø CYL. FIREGUARD®

PATENT: 5,695,089 PATENT: 5,809,650

CUSTOMER:

PROJECT:

QUOTE NO:

SCALE: 3/16"=1'-0"

DATE:

DWG. BY:

CHK'D BY:

DWG. NO:

AP6000FCG96DIKE