

NOTE: ALL RIGHTS RESERVED. THIS DRAWING MUST NOT BE REPRODUCED IN ANY FORM WITHOUT THE WRITTEN PERMISSION OF AREO POWER. AREO POWER SHALL BE RESPONSIBLE ONLY FOR ITEMS INDICATED ON THIS FABRICATION DRAWING UNLESS OTHERWISE NOTED. CUSTOMER IS RESPONSIBLE FOR VERIFYING CORRECTNESS OF SIZE AND LOCATION OF FITTINGS, ACCESSORIES, AND COATINGS SHOWN ON THIS DRAWING.

GENERAL SPECIFICATIONS

NO. REQ'D:

MODEL: 30 FIELD REVERSIBLE

MATERIAL: 304 STAINLESS STEEL 2-B FINISH

GAUGE OR THICKNESS OF MATERIAL

14 ga. THROUGHOUT

APPROX. WEIGHT: 137 lbs.

STATIC WATER CAPACITY: 17.1 gal

GREASE HOLDING CAPACITY: 90.5 lbs.

RETENTION TIME: 40.4 SEC.

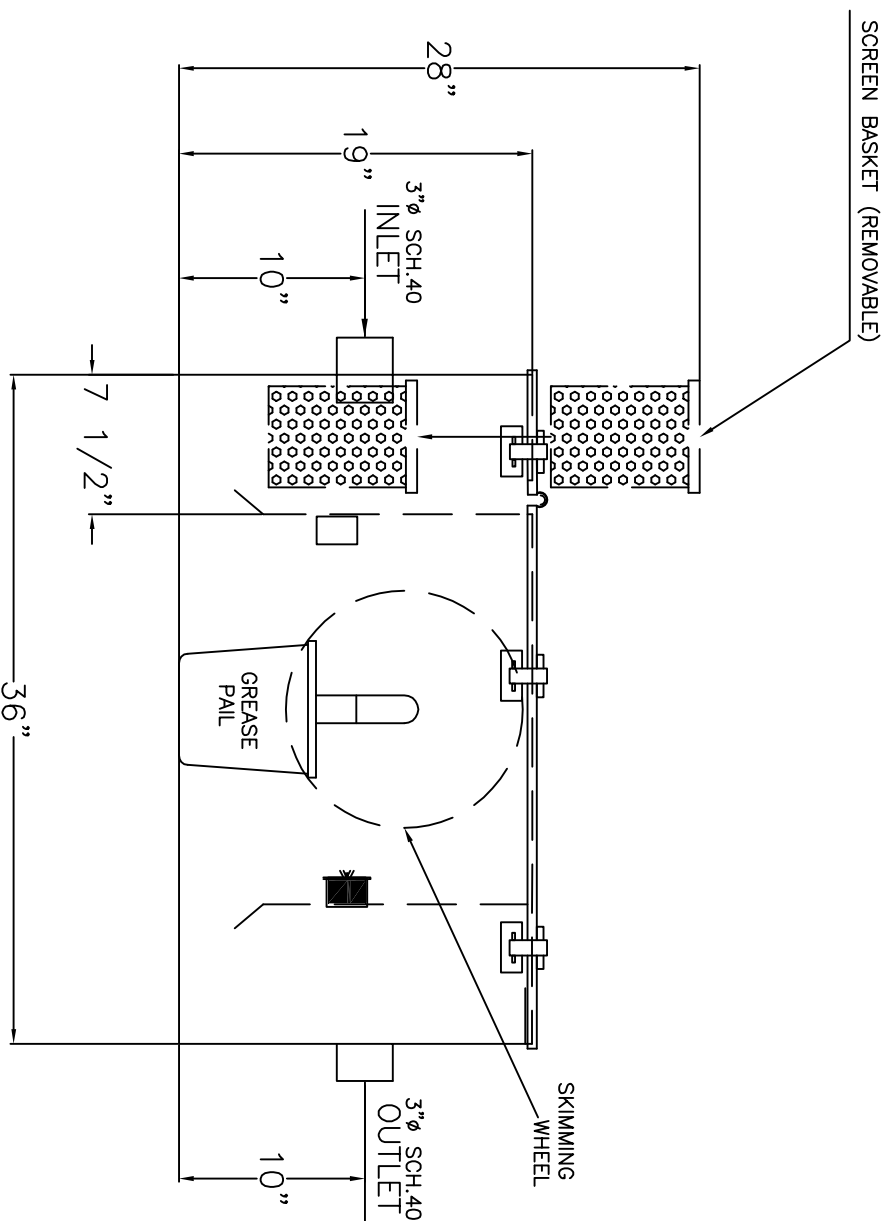
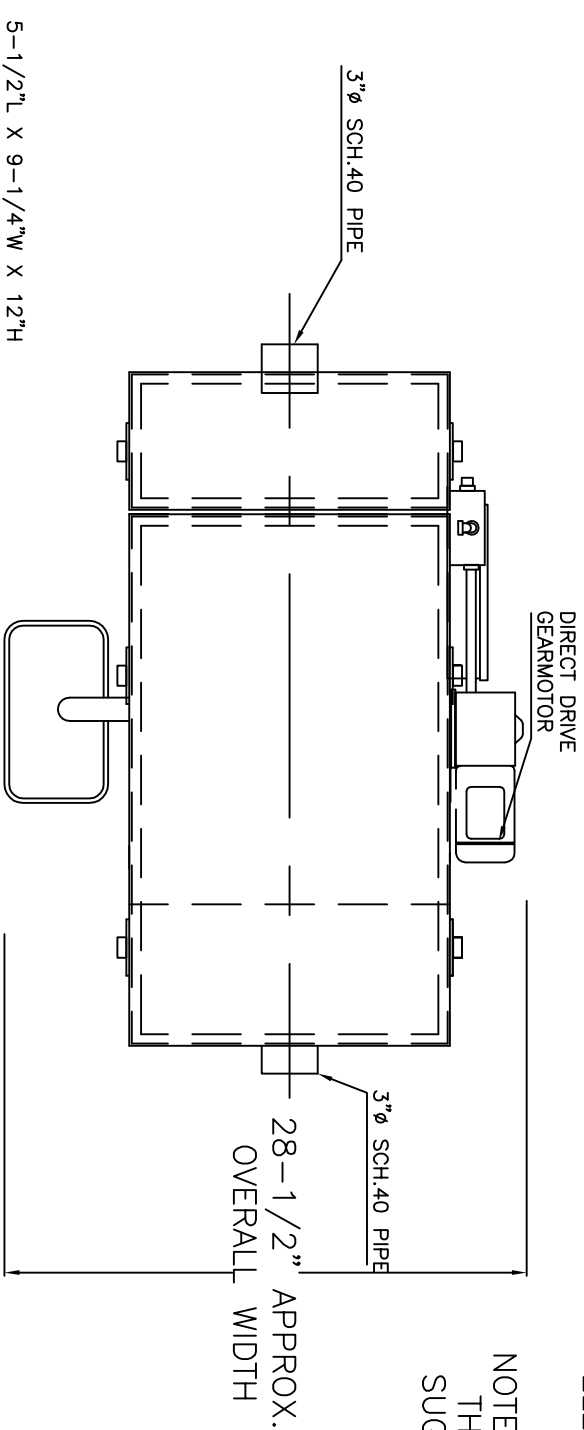
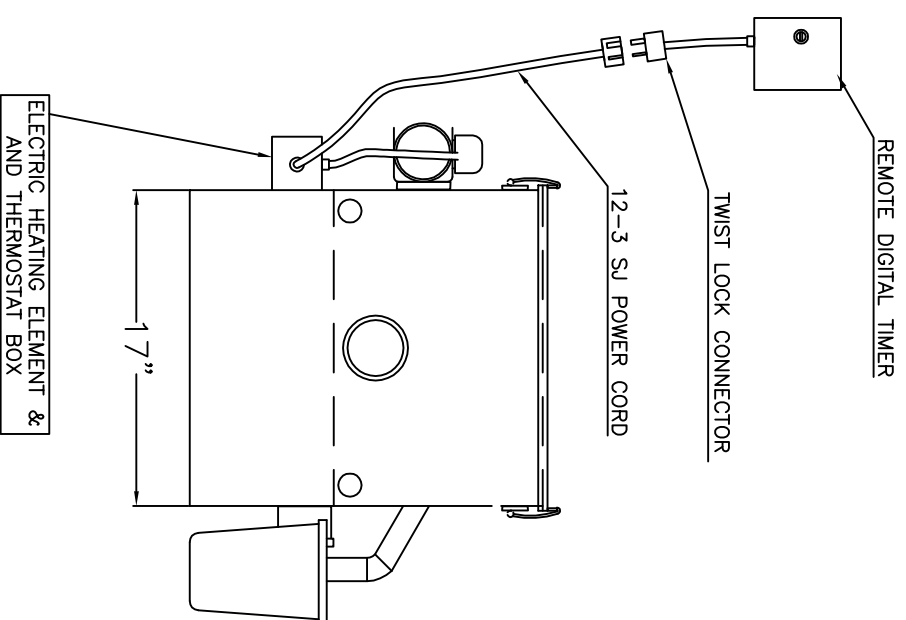

ELECTRICAL INFORMATION

UNIT MUST BE PLUGGED INTO A GFI(GROUND FAULT INTERRUPT)RECEPTACLE.

GEARMOTOR— .933 FLA. 115V, 60hz

ELECTRIC HEATING ELEMENT— 115 V, 1500 W

NOTE:

THE A.G.I. IS NOT A TRAP FOR SEWER GAS WE SUGGEST A TRAP DOWN STREAM FROM THE A.G.I.

LEFT TO RIGHT OR
RIGHT TO LEFT AS
NEEDED

REVISIONS	

GREASE STOPPER MODEL 30
FIELD REVERSIBLE

CUSTOMER:

PROJECT:

QUOTE NO.:

SCALE: 1"=1' DATE: 12/17/09 DWG. BY: CLO CHK'D BY: ARGO POWER 30 FR