

NOTE: ALL RIGHTS RESERVED. THIS DRAWING MUST NOT BE REPRODUCED IN ANY FORM WITHOUT THE WRITTEN PERMISSION OF HIGHLAND TANKS. HIGHLAND TANKS SHALL BE RESPONSIBLE FOR THE FABRICATION OF THIS TANK. FABRICATION DRAWING UNLESS OTHERWISE NOTED. CUSTOMER IS RESPONSIBLE FOR VERIFYING CORRECTNESS OF SIZE AND WEIGHT OF MATERIALS, FITTINGS, AND COATINGS SHOWN ON THIS DRAWING. TOUCH UP OF FINISHED PAINT IS REQUIRED BY INSTALLATION CONTRACTOR. TOUCH UP PAINT SHIPPED WITH TANK.

All rights reserved. This drawing or any part thereof must not be reproduced in any form without the written permission of Aero-Power Unified Fueler, Inc.

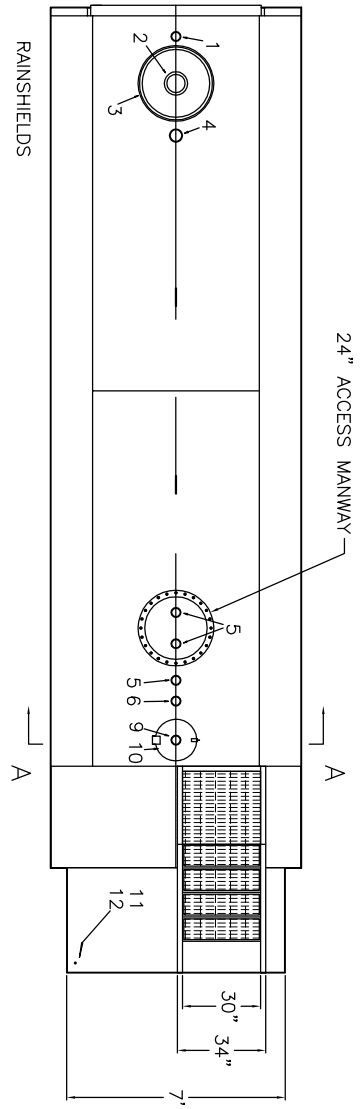

- NOTES
1. PRIMARY TANK: SHELL - 7 GA. HEAD - 7 GA CONTAINMENT: 1/4"
 2. MATERIAL - MILD CARBON STEEL
 3. TEST AT 5-7 PSIG.
 4. ENTIRE UNIT UL LISTED.
 5. EXTERIOR FINISH - PRIMER
 6. INTERIOR LINING - NONE
 7. ALL DIMENSIONS APPROXIMATE.

ITEM	DESCRIPTION
1	2" NORMAL VENT FITTING
2	6"-8 OZ. EMERGENCY VENT - SHIPPED LOOSE
3	VENT DEFLECTOR
4	4" FITTING
5	3" FITTING
6	3" FCPUG
7	-
8	-
9	4" FILL FITTING
10	FILL CONTAINMENT CHAMBER
11	DRIP PAN PLATFORM WITH 2" LIP
12	1/2" DRAIN FITTING
13	STAIRS, PLATFORM AND HANDRAIL-SHIPPED LOOSE
14	3/4" PUMPOUT PIPE
15	3" PIPE CAP SUMP
16	4" X 5.4# CH

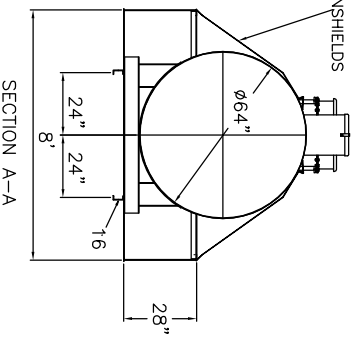
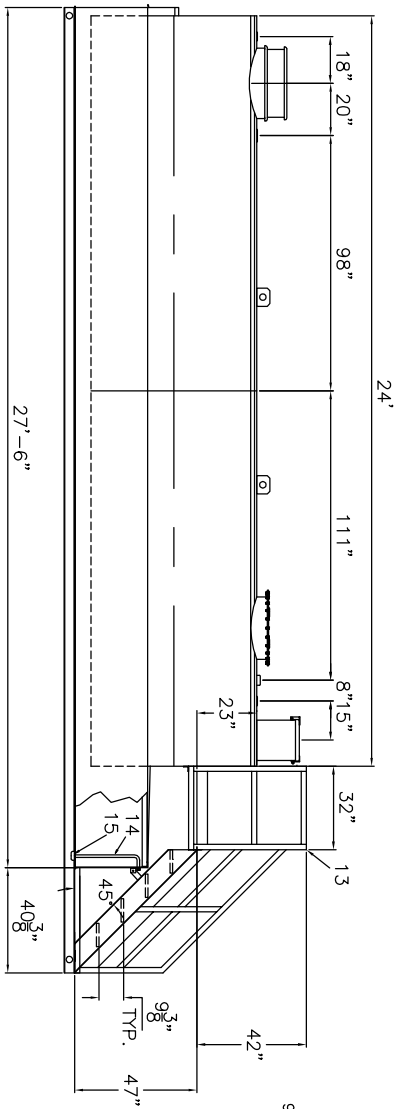

AREO-POWER®

4,000 GAL NASSUA CO. DIKE TANK

CUSTOMER: _____

PROJECT: _____

QUOTE NO: _____

SCALE: 1/4"=1'-0"

DWG. BY: _____

CHK'D BY: _____

DATE: _____

51931