

NOTE: ALL RIGHTS RESERVED. THIS DRAWING MUST NOT BE REPRODUCED IN ANY FORM WITHOUT THE WRITTEN PERMISSION OF AREO-POWER®. AREO-POWER® SHALL BE RESPONSIBLE ONLY FOR ITEMS INDICATED ON THIS FABRICATION DRAWING UNLESS OTHERWISE NOTED. CUSTOMER IS RESPONSIBLE FOR VERIFYING CORRECTNESS OF SIZE AND LOCATION OF FITTINGS, ACCESSORIES, AND COATINGS SHOWN ON THIS DRAWING.

TOUCH UP OF FINISHED PAINT IS REQUIRED BY INSTALLATION CONTRACTOR. TOUCH UP PAINT SHIPPED WITH TANK.

SHIPPING LUGS AS NEEDED

SHIP LOOSE  
(2) 8" FLANGED EMERGENCY VENTS

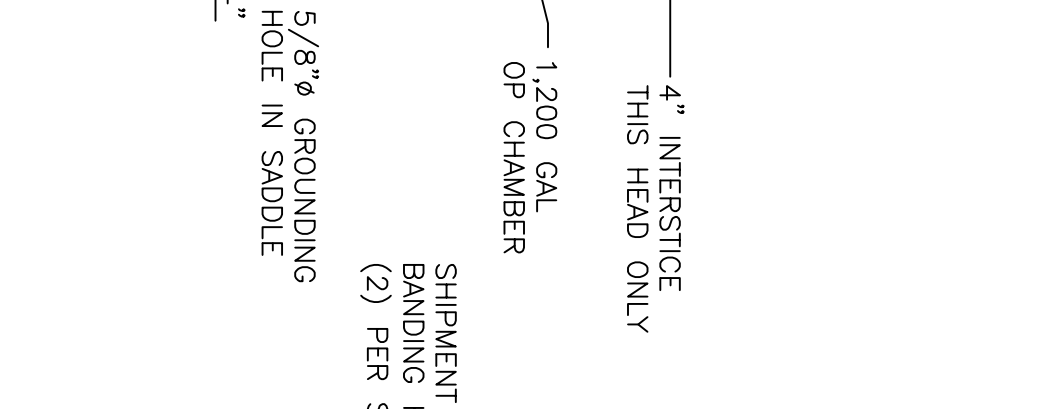
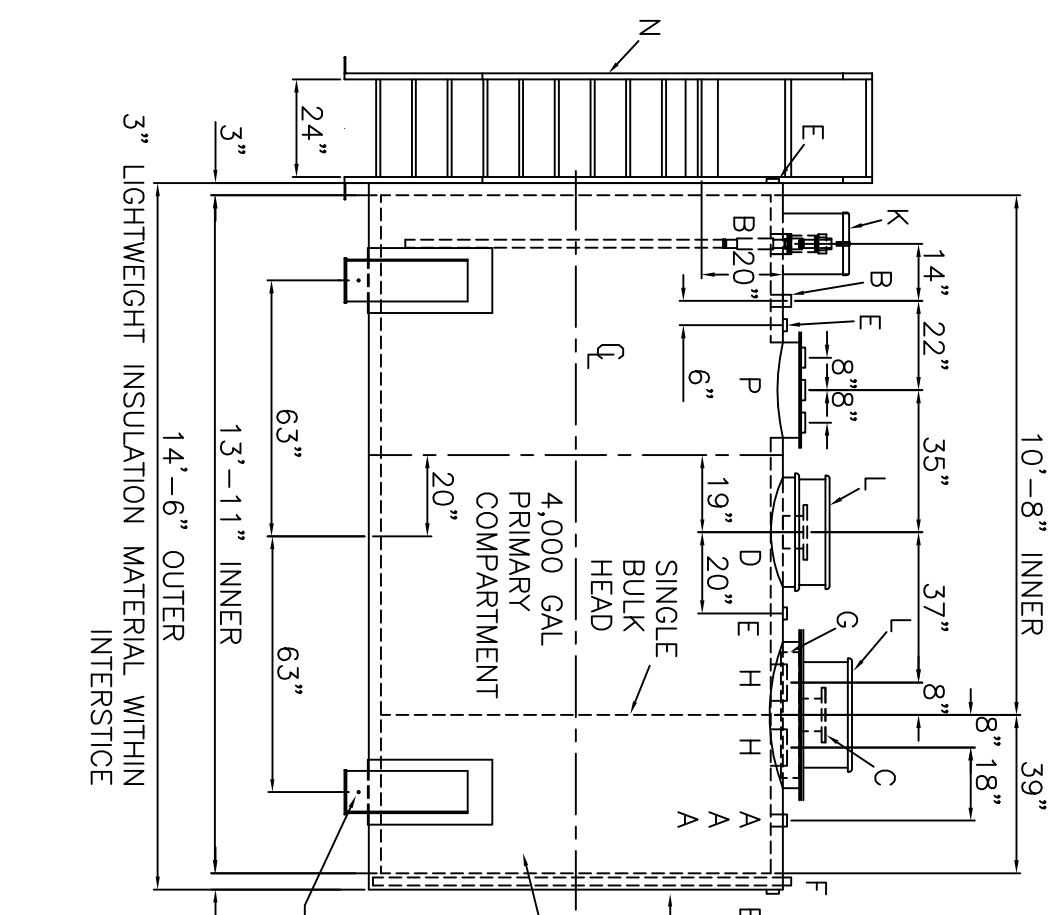
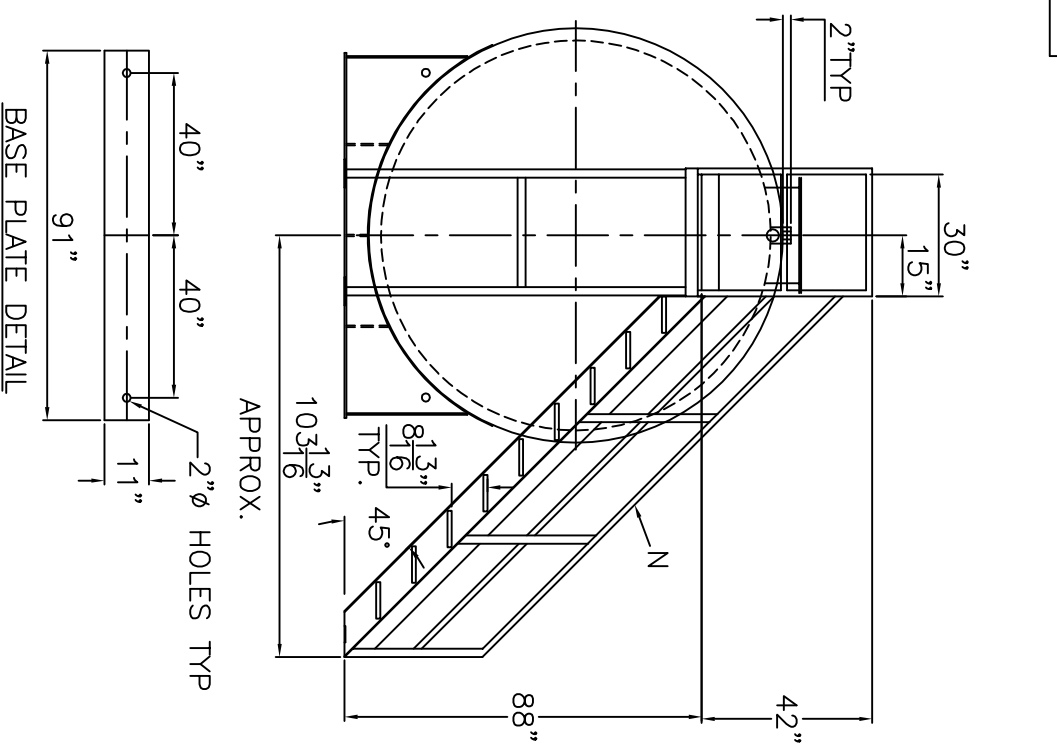

**DESIGN DATA**

CAPACITY : 4,000 GALLON
TYPE: FIREGUARD® CYLINDRICAL
FIREGUARD® IS A TRADEMARK OF THE STEEL TANK INSTITUTE
NO. REQ. - 1
OPERATING PRESSURE - ATMOSPHERIC
SPECIFIC GRAVITY = 1.0
TANK MATERIAL - MILD CARBON STEEL
THICKNESS - INNER- HEADS: 5/16", SHELL: 1/4"
THICKNESS - OUTER- HEADS: 5/16", SHELL: 1/4"
MIN. GAUGE OR THICKNESS (PER U.L. 2085)
CONSTRUCTION - INNER - LAP WELD OUTSIDE ONLY
CONSTRUCTION - OUTER - LAP WELD OUTSIDE ONLY
TANK TEST - PER UL 2085
INT. FINISH - NONE
EXT. FINISH - SP-6 BLAST, FINISH PAINT WHITE
LABEL- UL 2085 AND FIREGUARD® PER sti

**LEGEND**

A	2" FEMALE FIREGUARD COUPLING
B	4" FEMALE FIREGUARD COUPLING
C	8" FFSO 150# FLANGE - PRIMARY EMERGENCY VENT USE ONLY
D	8" FFSO 150# FLANGE THROUGH OUTER SHELL ONLY, MARK WITH SPECIAL WARNING LABEL INTERSTITIAL EMERGENCY VENT USE ONLY
E	2" FITTING THROUGH OUTER SHELL ONLY WITH CAST IRON PLUG- MFG USE ONLY
F	2" INTERSTITIAL MONITOR PIPE - MALE NPT END
G	31" LONG x 14" WIDE x 4" HIGH CLOSED TOP STEEL ENCLOSURE, WELDED TO TANK OUTER SHELL
H	8" FEMALE FIREGUARD COUPLING
J	36" x 1/4" PLATE TIGHT BOLT MANWAY WELDED TO TANK OUTER WALL ONLY, 1/8" THK. NEO-CORK GASKET AND EMERGENCY VENT CHAMBER - EXTENSION TO SHIP LOOSE FOR INSTALLATION ON SITE BY OTHERS
K	10 GAL SPILL CHAMBER WITH HINGE & HASP- APPROX 15"Ø X 13-1/2" HIGH, WELD TO TANK.
L	EMERGENCY VENT CHAMBER
M	INSTALLED 2" OVERFILL PREVENTION VALVE WITH 2" FEMALE THREADED TOP AND DROP PIPE VALVE TO BE SET FOR 90% OR 95% - PLEASE INDICATE DESIRED SETTING (CIRCLE ONE)
N	88" HIGH STANDARD AREO-POWER FREE STANDING STAIR & PLATFORM ASSEMBLY, PAINT: SAFETY YELLOW AND SHIP LOOSE FOR INSTALLATION ON SITE BY OTHERS
P	24" x 1/4" PLATE TIGHT BOLT MANWAY WITH 1/8" THICK NEO-CORK GASKET
Q	-

**NOTES:**

STRIKER PLATES ARE NOT SUPPLIED ON FIREGUARDS® UNLESS SPECIFIED

**AREO-POWER®**  
PATENT NUMBER 5346093

4,000 GAL 96"Ø CYL. FIREGUARD®

PATENT: 5,695,089 PATENT: 5,809,650

CUSTOMER:

PROJECT:

QUOTE NO:

SCALE: DATE: 1/4"=1'-0"

CHK'D BY: 7/7/89