

GENERAL SPECIFICATIONS

PAGE 1 OF 2 PAGES: SEE PAGE 2 FOR IMPORTANT GENERAL SPECIFICATIONS

NO. REQ'D: (1)
 CAPACITY: 4000 GALLON OIL WATER SEPARATOR
 TYPE: AREO-POWER, SINGLE WALL
 DESIGN: 10 P.P.M.
 15 P.P.M.
 MATERIAL: MILD CARBON STEEL
 ESTIMATED WEIGHT: 5760 lbs.
 FLOW RATE: 400 GPM

GAUGE:
 SHELL- 7GA
 HEADS- 7GA
 SURFACE PREP:
 SSPC NO.6 BLAST ALL EXTERIOR SURFACES
 SSPC NO.10 BLAST ALL INTERIOR SURFACES

COATING: MATERIAL THICKNESS
 EXTERIOR- S.T.I.P. 3 - CORROCOTE PLUS (15 MILS)
 ACT 100 U - FIBERTHANE (70 MILS)
 INTERIOR- CORROCOTE P.W. (15 MILS)

NOTE:

- INLETS, OUTLETS, & MANWAYS MUST BE VENTED. FAILURE TO VENT OUTLET CAN RESULT IN THE SYPHONING OF THE UNIT
- 15000 VOLT SPARK TEST PROVIDED AT FACTORY FOR FIBERTHANE TANK ONLY

PROVIDED EQUIPMENT

- 150# R.F.S.O. FLANGE
- ISOLATION SPOOL PIECE WITH INSULATION KIT
- VELOCITY HEAD DIFFUSION BAFFLE
- WEAR PLATE
- SEDIMENT CHAMBER
- UNDERFLOW BAFFLE
- REMOVABLE SLUDGE BAFFLE
- STRIKER PLATES
- SYNTHETIC PACK
- OIL/WATER SEPARATOR CHAMBER
- 5"Ø FTG. W/ 5"ØX4"Ø NYLON BUSHING FTG. FOR GAUGE WITH PLUG- TYP. BOTH MANWAYS
- OUTLET DOWNCOMER
- 30"Ø MANWAY WITH BOLT-ON EXTENSION SHIPPED LOOSE
- 5"Ø FTG. W/ 5"ØX4"Ø NYLON BUSHING FTG. FOR OIL PUMP-OUT WITH INTERNAL PIPE INSTALLED & RISER PIPE SHIPPED LOOSE
- 3"Ø FTG. W/ 3"ØX2"Ø NYLON BUSHING FTG. FOR LEVEL SENSOR
- LIFTING LUG
- 3"Ø FTG. W/ 3"ØX2"Ø NYLON BUSHING FTG. FOR VENT
- COALESCER PACKS WITH PULL ROD FOR 10 PPM MODEL ONLY
- SACRIFICIAL ZINC ANODES FOR S.T.I.P. 3 MODEL ONLY
- P.P.2 MONITORING LUG FOR S.T.I.P. 3 MODEL ONLY
- 3"Ø FTG. W/ 3"ØX2"Ø NYLON BUSHING FTG. FOR SENSOR CONDUIT

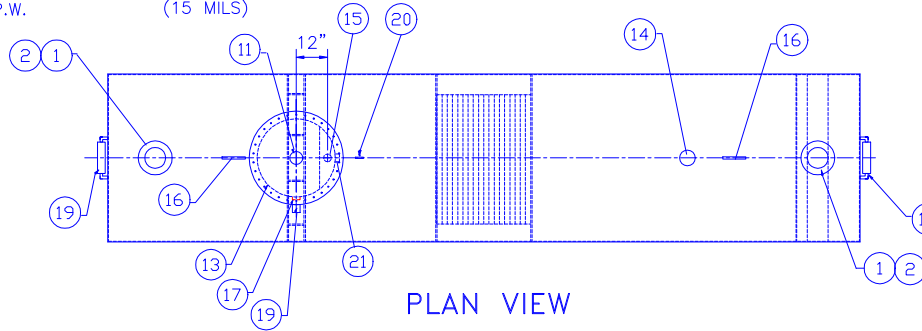

PLAN VIEW

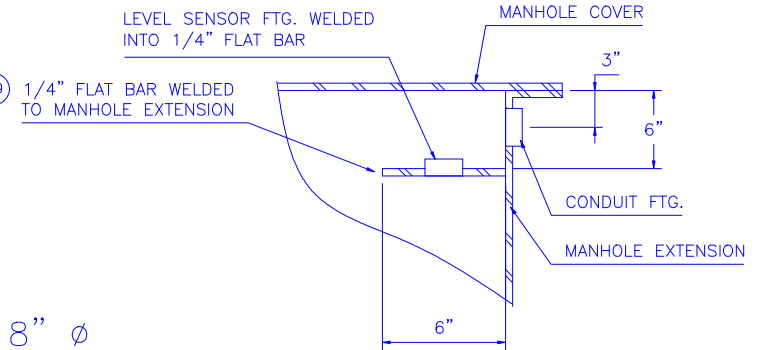

DETAIL-A

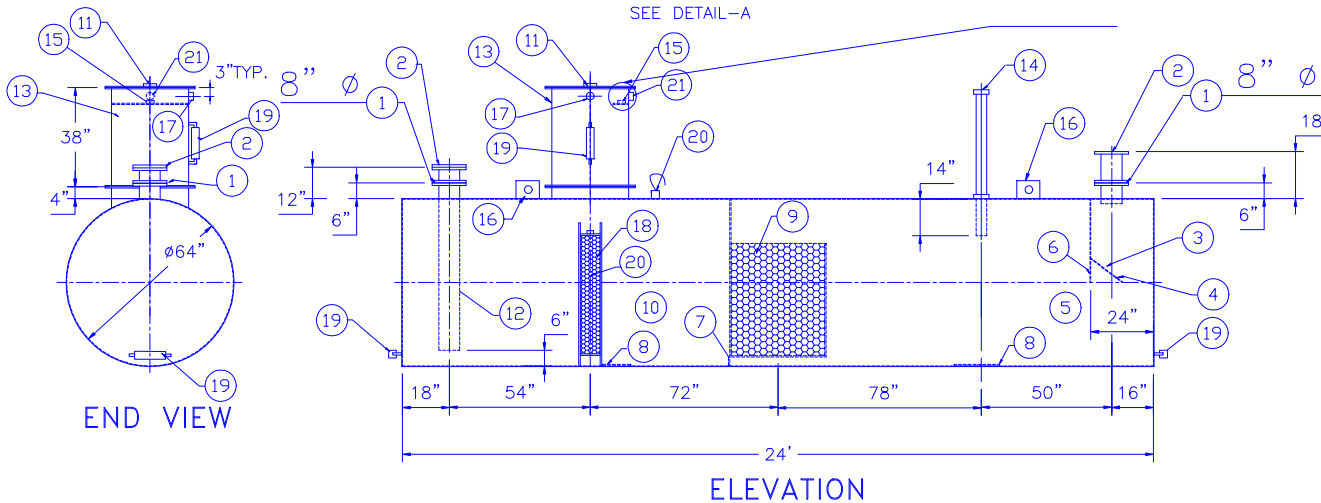

ELEVATION

AREO-POWER UNITIZED FUELER, INC.

OIL WATER SEPARATOR

103 SMITHTOWN BLVD. SMITHTOWN, NY 11787

ALL RIGHTS RESERVED. THIS DRAWING OR ANY PART THEREOF MUST NOT BE REPRODUCED IN ANY FORM WITHOUT WRITTEN PERMISSION OF ANY AREO-POWER UNITIZED FUELER, INC.

CUSTOMER:

QUOTE:

PROJECT:

SCALE: 1/4"=1'-0"	DATE:	DRN. BY:	CHKD BY:	DWG.# AP 4K SW SH
----------------------	-------	----------	----------	----------------------