

GENERAL SPECIFICATIONS

PAGE 1 OF 2 PAGES: SEE PAGE 2 FOR IMPORTANT GENERAL SPECIFICATIONS

NO. REQ'D: (1)
 CAPACITY: 5000 GALLON OIL WATER SEPARATOR
 TYPE: AREO-POWER, SINGLE WALL
 DESIGN: 10 P.P.M.
 15 P.P.M.
 MATERIAL: MILD CARBON STEEL
 ESTIMATED WEIGHT: 8082 lbs.
 FLOW RATE: 500 GPM

GAUGE:
 SHELL- .187"
 HEADS- 7GA
 SURFACE PREP:
 SSPC NO.6 BLAST ALL EXTERIOR SURFACES
 SSPC NO.10 BLAST ALL INTERIOR SURFACES

COATING: MATERIAL THICKNESS
 EXTERIOR- S.T.I.P. 3 - CORROCOTE PLUS (15 MILS)
 ACT 100 U - FIBERTHANE (70 MILS)
 INTERIOR- CORROCOTE P.W. (15 MILS)

NOTE:
 1. INLETS, OUTLETS, & MANWAYS MUST BE VENTED. FAILURE TO VENT OUTLET CAN RESULT IN THE SYPHONING OF THE UNIT
 2. 15000 VOLT SPARK TEST PROVIDED AT FACTORY FOR FIBERTHANE TANK ONLY

PROVIDED EQUIPMENT

1. 150# R.F.S.O. FLANGE
2. ISOLATION SPOOL PIECE WITH INSULATION KIT & 2" NPT FOR VENT
3. VELOCITY HEAD DIFFUSION BAFFLE
4. WEAR PLATE
5. SEDIMENT CHAMBER
6. UNDERFLOW BAFFLE
7. REMOVABLE SLUDGE BAFFLE
8. STRIKER PLATES
9. SYNTHETIC PACK
10. OIL/WATER SEPARATOR CHAMBER
11. 5"Ø FTG. W/ 5"ØX4"Ø NYLON BUSHING FTG. FOR GAUGE WITH PLUG- TYP. BOTH MANWAYS
12. OUTLET DOWNCOMER
13. 30"Ø MANWAY WITH BOLT-ON EXTENSION SHIPPED LOOSE
14. 5"Ø FTG. W/ 5"ØX4"Ø NYLON BUSHING FTG. FOR OIL PUMP-OUT WITH INTERNAL PIPE INSTALLED & RISER PIPE SHIPPED LOOSE
15. 3"Ø FTG. W/ 3"ØX2"Ø NYLON BUSHING FTG. FOR LEVEL SENSOR
16. LIFTING LUG
17. 3"Ø FTG. W/ 3"ØX2"Ø NYLON BUSHING FTG. FOR VENT
18. COALESCER PACKS WITH PULL ROD FOR 10 PPM MODEL ONLY
19. SACRIFICIAL ZINC ANODES FOR S.T.I.P. 3 MODEL ONLY
20. P.P.2 MONITORING LUG FOR S.T.I.P. 3 MODEL ONLY
21. 3"Ø FTG. W/ 3"ØX2"Ø NYLON BUSHING FTG. FOR SENSOR CONDUIT

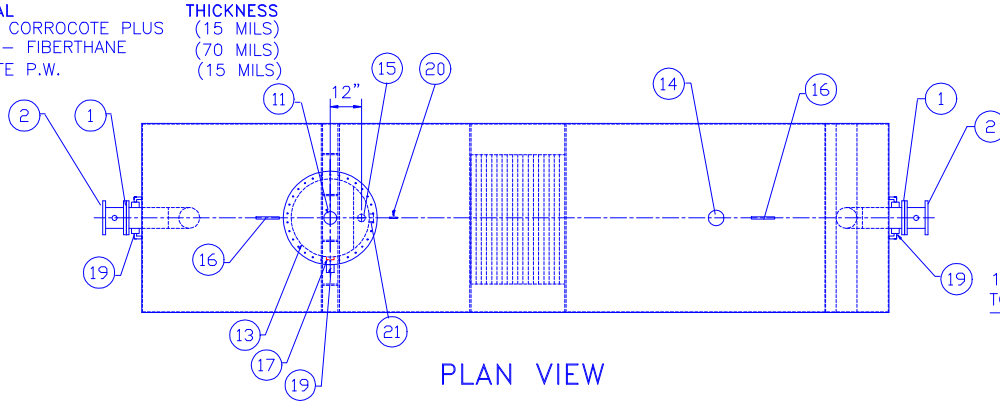

PLAN VIEW

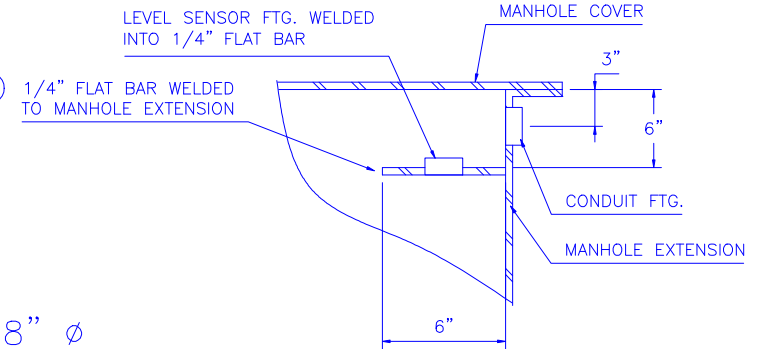

DETAIL-A

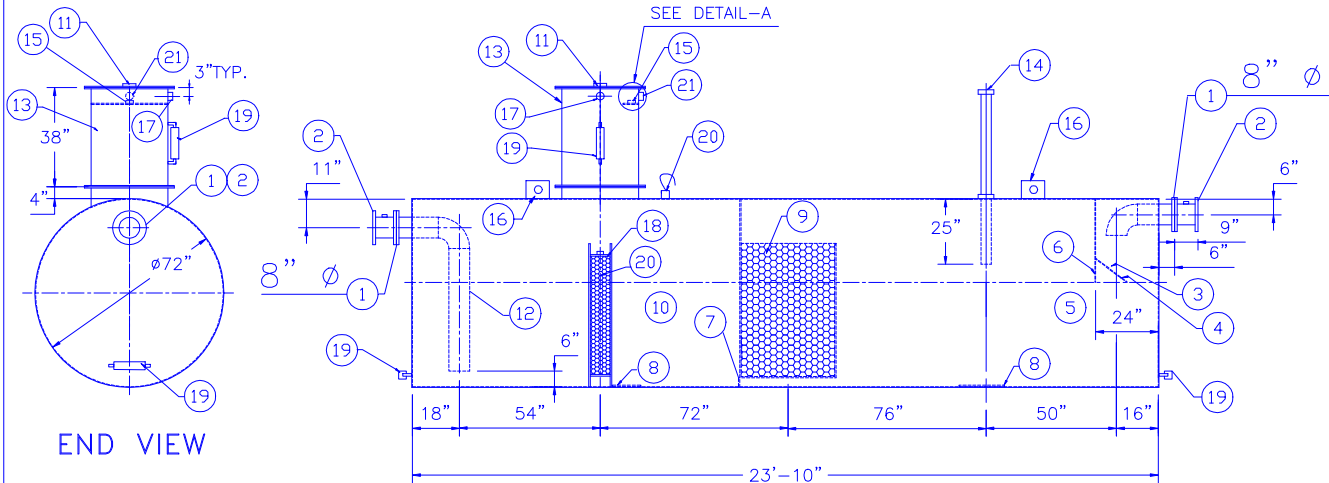

ELEVATION

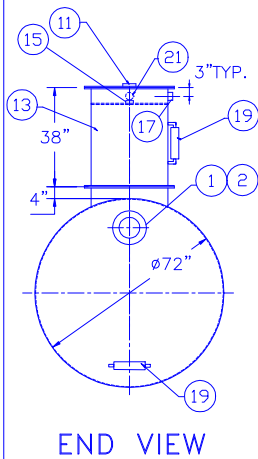

END VIEW

AREO-POWER
 UNITIZED FUELER, INC.

OIL WATER SEPARATOR
 103 SMITHTOWN BLVD. SMITHTOWN, NY 11787

ALL RIGHTS RESERVED. THIS DRAWING OR ANY PART THEREOF MUST NOT BE REPRODUCED IN ANY FORM WITHOUT WRITTEN PERMISSION OF ANY AREO-POWER UNITIZED FUELER, INC.

CUSTOMER:

QUOTE:

PROJECT:

SCALE: 1/4"=1'-0"	DATE:	DRN. BY:	CHKD BY:	DWG.# AP 5K SW HDS
----------------------	-------	----------	----------	-----------------------