

NOTE: ALL RIGHTS RESERVED. THIS DRAWING MUST NOT BE REPRODUCED IN ANY FORM WITHOUT THE WRITTEN PERMISSION OF AREO-POWER. AREO-POWER SHALL BE RESPONSIBLE ONLY FOR ITEMS INDICATED ON THIS FABRICATION DRAWING UNLESS OTHERWISE NOTED. CUSTOMER IS RESPONSIBLE FOR VERIFYING CORRECTNESS OF SIZE AND LOCATION OF FITTINGS, ACCESSORIES, AND COATINGS SHOWN ON THIS DRAWING.

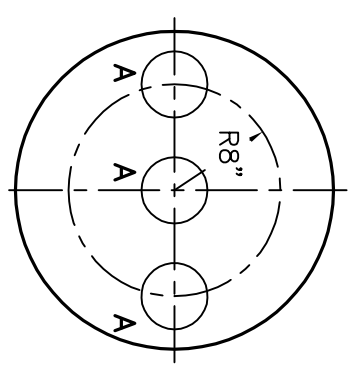

LID DETAIL D

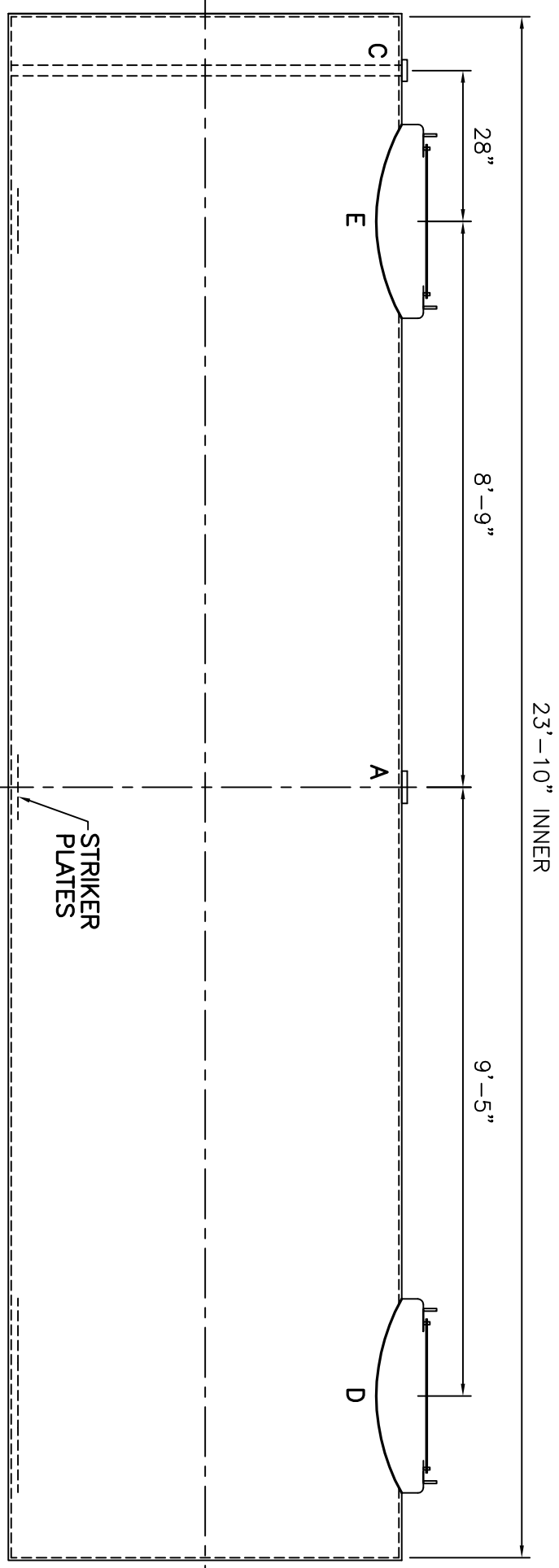
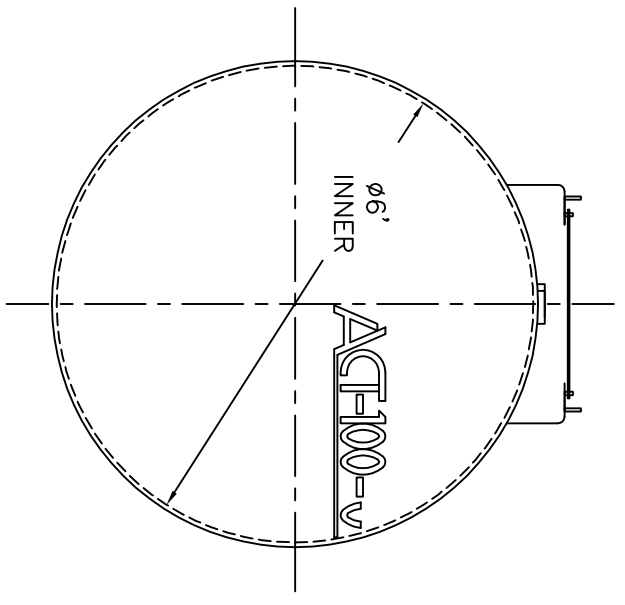
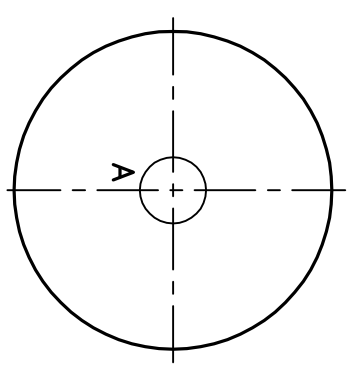

LID DETAIL E

**SPECIFICATIONS**

CAPACITY - 5000 GALLONS
TANK MATERIAL - MILD CARBON STEEL
THICKNESS - INNER - HEADS - 7 GAUGE SHELL - 7 GAUGE
THICKNESS - OUTER - HEADS - 7 GAUGE SHELL - 10 GAUGE
CONSTRUCTION - INNER - LAP WELD OUTSIDE ONLY
CONSTRUCTION - OUTER - LAP WELD OUTSIDE ONLY
TANK TEST - INNER - 5 PSIG OUTER - 2 PSIG AND FULL VACUUM
INT. FINISH - NONE
EXT. FINISH - SP6 BLAST, 70 MILS URETHANE PER stl SPEC
FACTORY SPARK TEST INCLUDED
LABEL - UL 58 & ACT-100-U DOUBLE WALL 360° TYPE I

**FITTING LEGEND**

<b>A</b>	5" FITTING WITH 5" X 4" DIELECTRIC BUSHING
<b>B</b>	-
<b>C</b>	3" FITTING WITH 3" X 2" DIELECTRIC BUSHING WITH INTERNAL MONITOR PIPE
<b>D</b>	24" DOUBLE RING MANWAY W/FITTINGS PER DETAIL
<b>E</b>	24" DOUBLE RING MANWAY W/FITTING PER DETAIL
<b>F</b>	-

<b>AREO-POWER</b> ®			
<b>5000 GAL 360° DW ACT-100-U</b>			
CUSTOMER: -			
PROJECT: -			
QUOTE: -			
SCALE	DATE	DRAWN BY	
7/16" = 12"	2/09/01	XXX	
DWG. NO. <b>APAUDW5K6</b>			